

BA 001E/FM4000i/02.26

Valid starting from
Hardware V 4.1
Software V 1.50

Flowmax[®] 4000i

Ultrasonic flow metering / dosing device

Operating manual

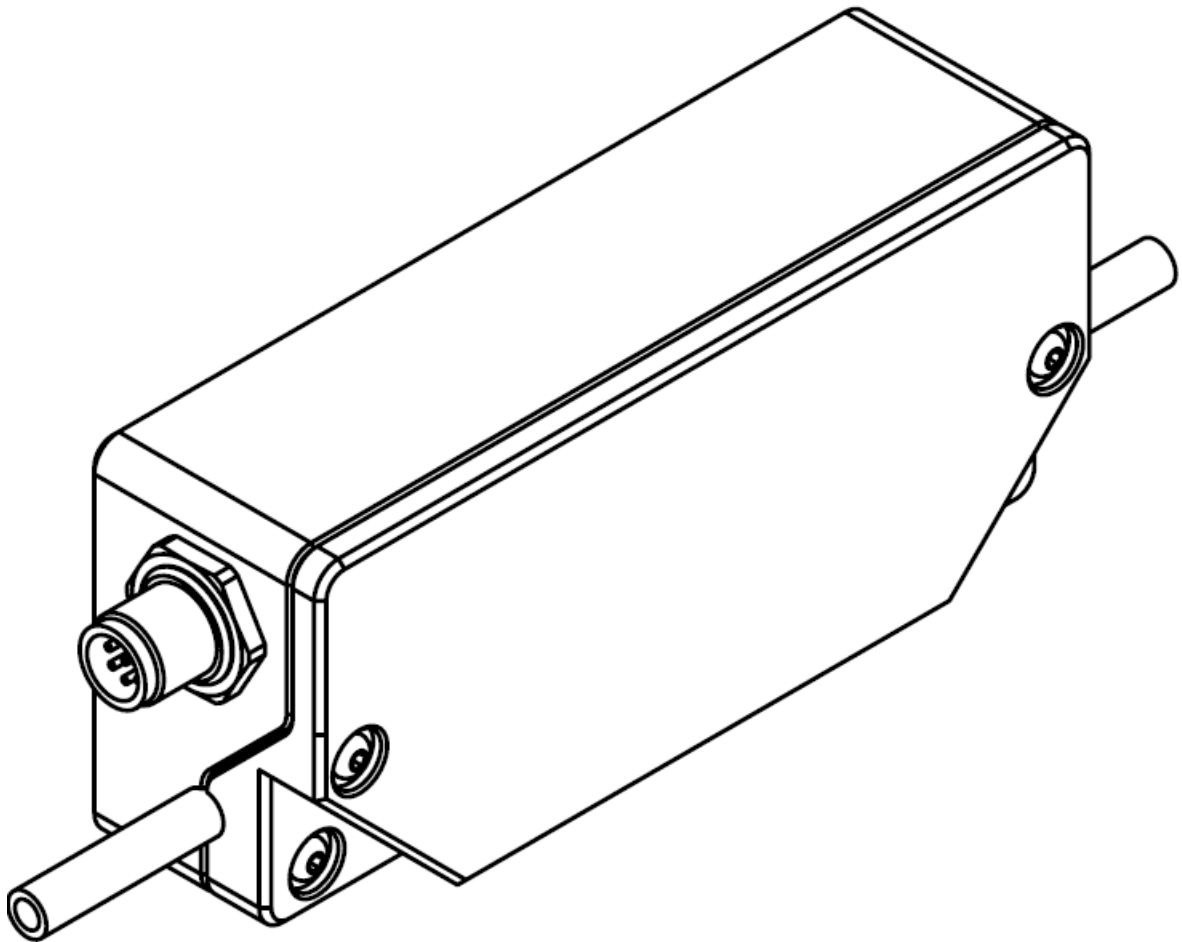

General safety instructions

Please always observe the following safety instructions!

Please pay attention to the safety instructions with the following pictograms and signal words in these operating instructions:

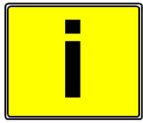

IMPORTANT!

IMPORTANT! indicates situations or cases which, if not avoided, could result in damage or failure of the Flowmax 4000i equipment.



WARNING!

WARNING! indicates general hazardous situations or cases which, if not avoided, could result in serious injury or death.

NOTICE!

NOTICE! is used to lead users to helpful information not related to personal injury.

Intended use

- The flowmeter Flowmax 4000i may only be used for measuring the flow of pure, homogeneous liquids.
- The Flowmax 4000i is not intended for use in medical applications.
- The manufacturer is not liable for any injury, damage or harm due to inappropriate or unintended use or modifications of the flowmeter. Conversions and/or changes to the flowmeter may only be made, if they are expressly performed in accordance with the operating instructions in this operating manual.

Personnel for installation, commissioning and operation

- Mounting, electrical installation, commissioning and maintenance of the measuring device may only be carried out by trained specialist personnel who have been authorized to do such work by the system operator. The qualified personnel must have read and understood these operating instructions and follow them.
- The person carrying out the installation must ensure that the flow meter is connected correctly in accordance with the electrical connection diagrams.



WARNING!

Disposal

In accordance with Directive 2002/96/EC of the European Parliament and of the Council of January 27, 2003 on waste electrical and electronic equipment and the national law on the marketing, return and environmentally friendly disposal of electrical and electronic equipment (Electrical and Electronic Equipment Act - ElektroG) of March 16, 2005, we commit ourselves to take back this device, which we placed on the market after August 13, 2005, free of charge at the end of its useful life and to dispose of it in accordance with the above-mentioned directives. As this appliance is used exclusively for commercial purposes (B2B), it may not be handed in to public waste disposal services.



Technological progress

The manufacturer reserves the right to adapt technical data to technical development progress without prior notice. Please contact MIB for information on the current status and any updates of these operating manual.

Table of contents

Table of contents	3
Table of figures	3
1. Planning information	4
1.1 Areas of application.....	4
1.2 Measuring principle.....	4
1.3 Operational safety.....	5
2. Assembly and installation	5
2.1 Installation instructions.....	5
2.2 Assembly of the flowmeter.....	6
2.3 Electrical wiring.....	7
3. Commissioning	11
3.1 Operation.....	11
3.2 Functionalities of flowmeter and default settings.....	11
3.2.1 Media.....	11
3.2.1.1 Set offset.....	11
3.2.1.2 Flow measurement damping.....	12
3.2.1.3 Creeping suppression.....	12
3.2.2 Analog output QA.....	13
3.2.2.1 Function.....	13
3.2.2.2 Output value.....	15
3.2.3 Digital outputs Q1 and Q2.....	15
3.2.3.1 Pulse value.....	15
3.2.4 Digital input I1.....	16
3.3 Overview of default settings.....	16
3.4 General information.....	16
4. Exchange of flowmeter	17
5. Technical specifications	18
5.1 Dimensions and weight.....	18
5.2 Technical specifications.....	19
6. Accessories	19
7. Shipment	19

Table of figures

Figure 1: Presentation of the principle of ultrasonic flow measuring.....	4
Figure 2: Installation position of Flowmax 4000i.....	5
Figure 3: Mounting examples for Flowmax 4000i.....	6
Figure 4: Mounting possibilities.....	6
Figure 5: Fixing Flowmax 4000i.....	7
Figure 6: Pin code: Connection plug / socket for 5-pin version.....	7
Figure 7: Pin code: Connection plug / socket for 8-pin version.....	9
Figure 8: Step response of the outputs.....	12
Figure 9: Function of creeping suppression illustrated with 0.6 l/min.....	12
Figure 10: Characteristic curve 0 ... 20mA.....	13
Figure 11: Characteristic curve 4 ... 20mA.....	14
Figure 12: Characteristic curve.....	14
Figure 13: Connecting Digital output to counter.....	15

1. Planning information

1.1 Areas of application

The flow measurement device Flowmax 4000i is designed to measure dynamic flow in pipes and tubes. This flowmeter is suitable for liquids only. The Flowmax 4000i is used in

- Chemicals supply for controlling, logistics, monitoring
- Cooling systems, logistics, monitoring
- Process equipment for control and monitoring of formulas
- Valve control for continuous release of liquid volumes
- Supply with de-ionized water

Flowmax 4000i has the following features and benefits:

- No movable parts, therefore no wear
- High repeatability
- Easy to clean
- Safe operation
- Compact design
- Integrated detection of empty conduits
- Chemical resistant

1.2 Measuring principle

It usually takes more energy to swim against the flow than with the flow. The ultrasonic flow measurement is based on the time of flight difference approach: Two ultrasonic-sensors located opposite from each other alternatively transmitting and receiving ultrasonic signals. If there is no liquid flow both sensors receive the transmitted ultrasonic signals in the same time, i.e. without time delay. If liquid is flowing there is a time shift. It differs when measured in direction of the flow than when measured against the direction of the flow. This time difference is directly proportional to the flow rate.

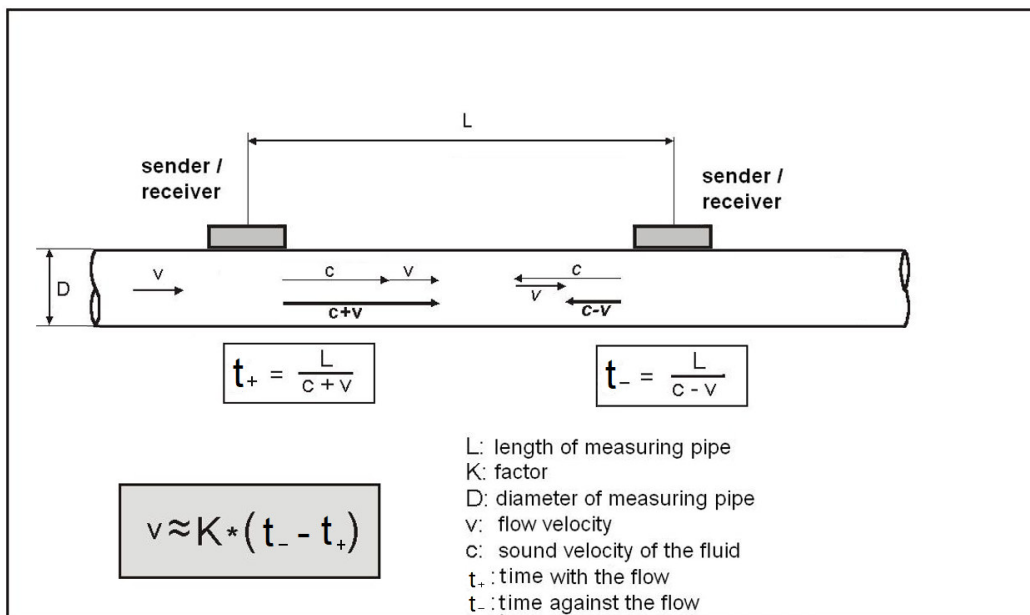

Figure 1: Presentation of the principle of ultrasonic flow measuring

1.3 Operational safety

Comprehensive self-tests ensure highest possible safety.

Faults (process or system errors) are output on a digital output or displayed on the display menu.

The protection class is IP65.

2. Assembly and installation

2.1 Installation instructions

The housing of Flowmax 4000i is labeled with an arrow symbolizing the direction of the flow measurement. The flow meter has to be installed in a way so that the flow-through is in the same direction as the arrow symbol.

NOTICE!

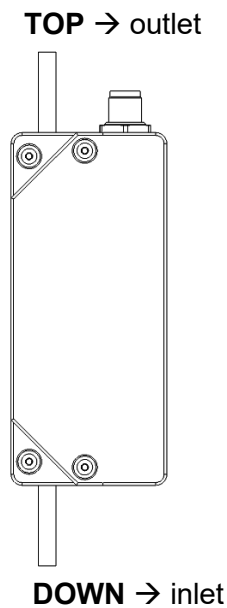

Figure 2: Installation position of Flowmax 4000i

For fastest possible bubble detection it is important to keep the pipe distance from tank to Flowmax 4000i as short as possible. Accurate measurement can only be assured, if the pipe is completely filled and the liquid does not outgas.

Notwithstanding it may be advantageous for dosing applications to install the Flowmax 4000i as close as possible to the dosing valve, as soft pipes change the cross-section depending on the system pressure. This may lead to repeatable differences.

Insure that no cavitations dissolve from the measured liquid. Depending on the measured liquid it can be helpful to have enough back pressure on the outlet of Flowmax 4000i to avoid cavitations. Insure all mechanical connections are tight.

NOTICE!

Particles present in the flow stream may result in measuring errors.

When using pumps, Flowmax 4000i must be installed behind the pump in the flow direction, on the pressure side, to ensure that sufficient pressure is available. The maximum pressure rating of the Flowmax 4000i must be taken into account.

For correct volume flow measurement, straight and undisturbed inlet and outlet sections must be maintained for Flowmax 4000i. Depending on the nominal diameter, these are at least:

2.2 Assembly of the flowmeter

The flowmeter is mounted into a pipe system by using the mechanical connection. Flowmax 4000i should be mounted vertically into the pipe for the best measuring performance. Do not install the flowmeter after a dosing valve where the flowmeter can run empty. Placing the flowmeter after a dosing valve and allowing it to run empty will cause a measuring deviation at the next measurement. To avoid bubbles in the liquid, Flowmax 4000i should be installed on the pressure side of the pump.

NOTICE!

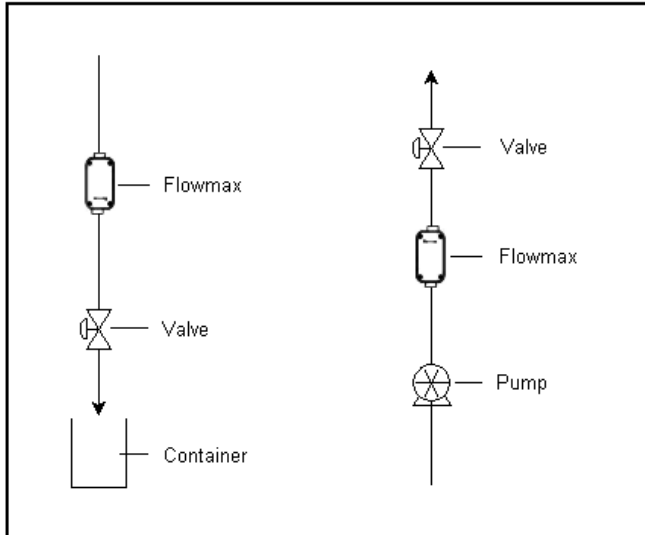

Figure 3: Mounting examples for Flowmax 4000i

If it is not possible to mount the flowmeter vertically, then mount the instrument in a location where the pipe will be filled at all times. The best measuring result is achieved if bubbles do not pass through Flowmax 4000i.

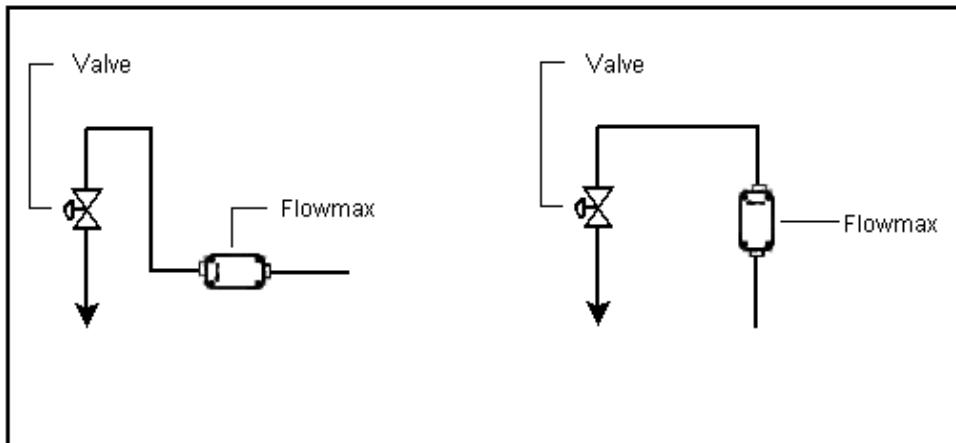

Figure 4: Mounting possibilities

For applications with a “clean design“ for which it is necessary to completely drain the pipe system, we recommend mounting the flowmeter in the vertical position. Residual liquid may remain inside the device if flowmeter is mounted horizontally.

Vibrations or mechanical forces may decrease measuring accuracy. Mounting the flowmeter using two screws will reduce vibrations or movements. Use the screws as seen in the figure below at the housing of Flowmax 4000i.

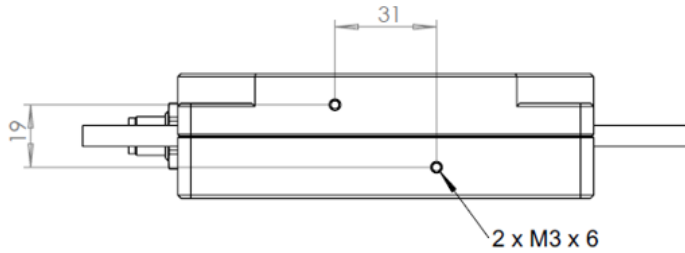

Figure 5: Fixing Flowmax 4000i

IMPORTANT!

Flowmax 4000i must be installed without mechanical tensions. The flowmeter may be damaged if there is tension on the existing pipe system.



IMPORTANT!

2.3 Electrical wiring

Do not install, wire or dismantle the measuring device while it is under operating voltage. The supply voltage to the Flowmax 4000i must be switched off during these procedures.



WARNING!



Figure 6: Pin code: Connection plug / socket for 5-pin version

5-pin plug assignment with factory-assigned outputs

The inputs and outputs can be parametrized for specific applications.

5-pin plug with 1-wire communication:

Pin	Function	Description
1	24 VDC	Power supply: 18 ... 30 VDC
2	Digital Output Q1	Freely adjustable in the range from 0.001 to 50 ml/pulse, in steps of 0.001. Bipolar 0...24 V Maximum load 100 mA The pull-up voltage is not allowed to be higher than the power supply voltage.
	1. Pulse Output	Output in ml/pulse, depending on the pulse value setting.
	2. Empty Pipe	Output of 0V or 24V when the measuring pipe is empty or too many bubbles/particles detected.
3	GND	Power supply ground: 0 V
4	Communication	Communication interface
5	Analog Output QA	4 ... 20mA; 0 ... 20mA; 0 ... 5V; 1 ... 5V; 0 ... 10V; 2 ... 10V
		For example: 0l/min → 4mA 36l/min → 20mA (depending on the nominal diameter) Empty pipe alarm → 3,5mA

5-pin plug with RS 485 – communication and digital output Q1:

Pin	Function	Description
1	24 VDC	Power Supply: 18 ... 30 VDC
2	Digital Output Q1	Freely adjustable in the range from 0.001 to 50 ml/pulse, in steps of 0.001. Bipolar 0...24 V Maximum load 100 mA The pull-up voltage is not allowed to be higher than the power supply voltage.
	1. Pulse Output	Output in ml/pulse, depending on the pulse value setting.
	2. Empty Pipe	Output of 0V or 24V when the measuring pipe is empty or too many bubbles/particles detected.
3	GND	Power supply ground: 0 V
4	Communication	RS485A
5	Communication	RS485B

8-pin plug with 1-wire communication:

Figure 7: Pin code: Connection plug / socket for 8-pin version

8-pin plug assignment with factory-assigned outputs

Pin	Function	Description
1	24 VDC	Power Supply: 18 ... 30 VDC
2	Digital Output Q1	Freely adjustable in the range from 0.001 to 50 ml/pulse (or ml/s/Hz), in steps of 0.001. Bipolar 0...24 V Maximum load 100 mA The pull-up voltage is not allowed to be higher than the power supply voltage
	1. Pulse Output	Output in ml/pulse, depending on the pulse value setting.
	2. Empty Pipe	Output of 0V or 24V when the measuring pipe is empty or too many bubbles/particles detected.
3	GND	Power supply ground: 0 V
4	Digital Output Q2	Freely adjustable in the range from 0.001 to 50 ml/pulse (or ml/s/Hz), in steps of 0.001. Bipolar 0...24 V Maximum load 100 mA The pull-up voltage is not allowed to be higher than the power supply voltage
	1. Pulse Output	Output in ml/pulse, depending on the pulse value setting.
	2. Empty Pipe	Output of 0V or 24V when the measuring pipe is empty or too many bubbles/particles detected.
5	Analog Output QA	4 ... 20mA; 0 ... 20mA; 0 ... 5V; 1 ... 5V; 0 ... 10V; 2 ... 10V
		For example: 0l/min → 4mA 36l/min → 20mA (depending on the nominal diameter) Empty pipe alarm → 3,5mA
6	Communication	Communication interface
7	Digital input I1	Set Offset Starts zero flow adjustment, at 24V
8	Shield	EMC safety

* Q1 + Q2 ≤ 100mA

8-pin plug with RS 485 communication:



Pin code: Connection plug / socket for 8-pin version

Pin	Function	Description
1	24 VDC	Power supply: 18 ... 30 VDC
2	Digital Output Q1	Freely adjustable in the range from 0.001 to 50 ml/pulse (or ml/s/Hz), in steps of 0.001. Bipolar 0...24 V Maximum load 100 mA The pull-up voltage is not allowed to be higher than the power supply voltage
	1. Pulse Output	Output in ml/pulse, depending on the pulse value setting.
	2. Empty Pipe	Output of 0V or 24V when the measuring pipe is empty or too many bubbles/particles detected.
3	GND	Power supply ground: 0 V
4	Digital input I1	Set Offset Starts zero flow adjustment, at 24V
5	Analog Output QA	4 ... 20mA; 0 ... 20mA; 0 ... 5V; 1 ... 5V; 0 ... 10V; 2 ... 10V
		For example: 0l/min → 4mA 36l/min → 20mA (depending on the nominal diameter) Empty pipe alarm → 3,5mA
6	Communication	RS485A
7	Communication	RS485B
8	Shield	EMC safety

ATTENTION:

The Flowmax 4000i measuring device may only be operated within the limits specified on the nameplate and in the operating manual/data sheet. Unauthorized operating conditions can lead to overloads, damage or defects.



IMPORTANT!

3. Commissioning

NOTE:

After starting up the electronics, the device is ready for use, but it reaches its optimum operating state after 30 minutes. It makes sense to carry out a set offset adjustment only after this warm-up phase.

NOTICE!

NOTE:

If Flowmax 4000i is used for a fluid other than water the "set offset" has to be carried out during commissioning. Therefore, the device has absolutely be filled with medium.

NOTICE!

The set offset can be done via the digital input. During the adjustment, the medium may not flow, as this can lead to a measurement deviation. If there is a possible flow, it will be stored as "zero point".

3.1 Operation

If Flowmax 4000i is used as a flowmeter for water or water-like liquids, it generally requires no on-site operation, as the parameters listed below have a factory setting that ensures optimal function. However, Flowmax 4000i can also be supplied with customer-specific settings.

NOTE: If necessary, e.g. if viscosity and/or speed of sound deviate significantly from water, the pre-set parameters can be adjusted via the digital input with the set offset function.

NOTICE!

The following parameters may be changed to settings suitable for the individual conditions: for 8-pin version

- Digital output Q1, function and behavior
- Digital output Q2, function and behavior (optionally)
- Digital input I1, set offset
- Analog output QA, function and behavior
 - o Flow range, for which shall apply 4 ... 20 mA; 0 ... 20mA; 0 ... 5V; 1 ... 5V; 0 ... 10V; 2 ... 10V
- Pulse value

3.2 Functionalities of flowmeter and default settings

3.2.1 Media

3.2.1.1 Set offset

By using the digital input, it is possible to perform a "set offset.". Use this function only when Flowmax 4000i is completely filled with liquid and there is no flow, as this condition is the new "zero" value.

Duration: 0.5s

Flowmax 4000i automatically does a small offset change, e.g. caused by variable temperatures.

IMPORTANT!

The "Set Offset" input function may only be carried out when the device is absolutely filled and the medium has been at a standstill for at least 30 seconds. If a Set Offset is carried out when the flow is active, incorrect measurements will occur until the adjustment has been carried out correctly. This adjustment should only be performed after the device has been powered on for more than 30 minutes and when the process conditions have stabilized.



IMPORTANT!

3.2.1.2 Flow measurement damping

Digital and analog outputs have the same damping. The damping can be set from 0.1s – 6s for 63%. The standard setting is:

63% after 0.6 s

97% after 2.0 s

99% after 2.5 s

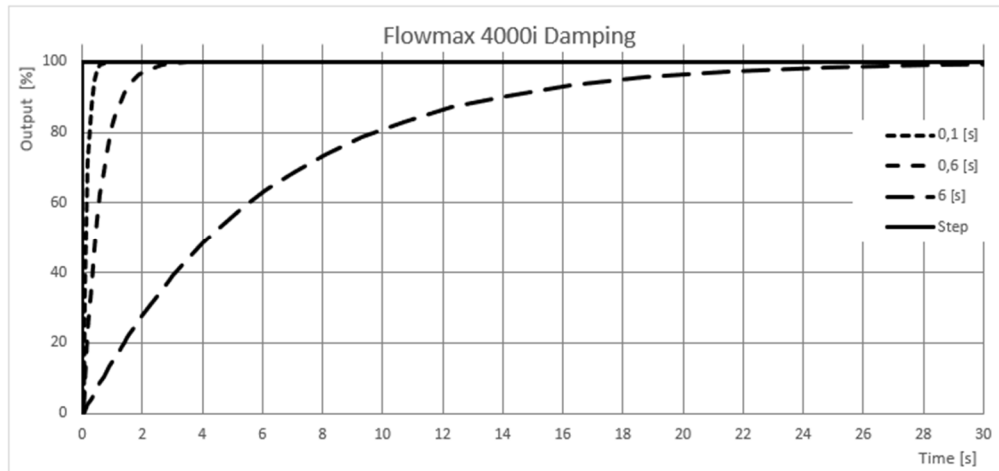

Figure 8: Step response of the outputs

3.2.1.3 Creeping suppression

Creeping flow suppression is used to exclude flows from the measurement that can occur within a narrow range around zero, even when the valve is closed, due to convection. The factory setting of the creeping flow suppression is set to a sensible standard value in relation to the cross-section of the measuring device.

Creeping suppression works with a hysteresis of 0% to - 25%.

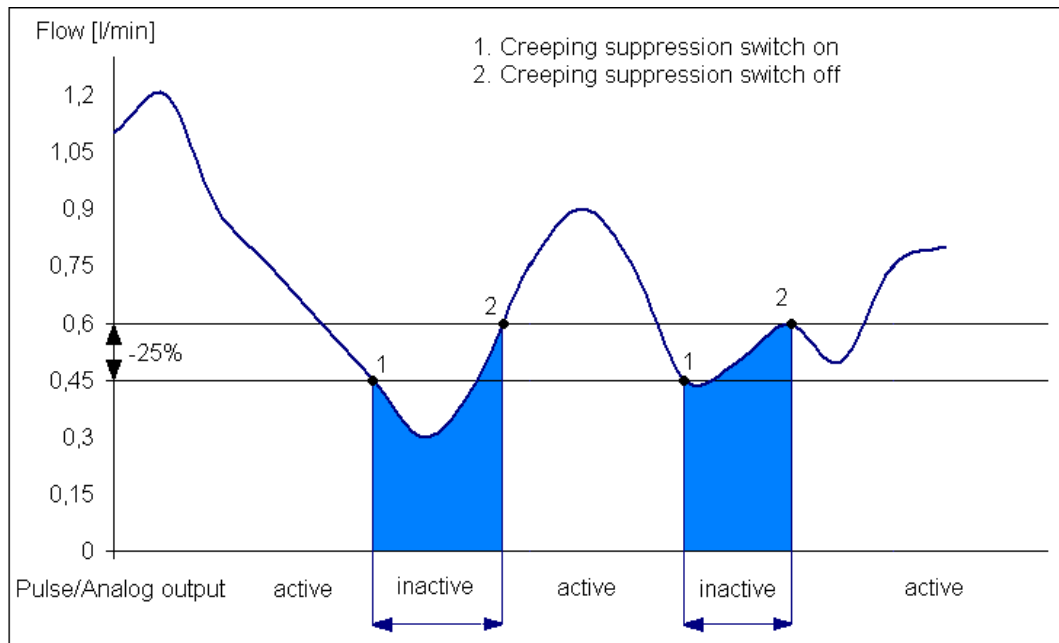

Figure 9: Function of creeping suppression illustrated with 0.6 l/min

Example: Creeping suppression = 0.6 l/min

If the flow rate falls below a value of 0.45 l/min, creeping flow suppression is activated. If the flow rate exceeds 0.6 l/min, the flow rate is again output as a pulse and a value is also displayed to the analog output again.

Default settings: 1/4": 0.17 [ml/s]
 1/8": 0.042 [ml/s]

3.2.2 Analog output QA

3.2.2.1 Function

The Analog Output is an active output with 0 ... 10V.

Setting range: 0 ... 20mA, 4 ... 20mA,
0 ... 5V, 1 ... 5V, 0 ... 10V, 2 ... 10V, Off
Default setting: 4 ... 20mA

Max range and min range parameters can be set within the type-specific measurement of the device. The value of the max range must be greater than the value of the min range, so that the values are stored. By default, the min range is 4mA and the respective end of the measuring range is set to 20mA.

IMPORTANT!

If the voltage output is used, the minimum resistance R_i should not be less than 500 Ohm, otherwise it can't be guaranteed that the measuring device can deliver the maximum value.

If the current output is used, the maximum resistance R_i should not be bigger than 500 Ohm, otherwise it can't be guaranteed that the measuring device can deliver the maximum value.

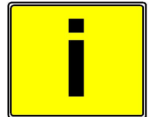

IMPORTANT!

Characteristic curves analog output 0 ... 20mA

For the following graphic “min Range” is used for 0% and “max Range” is used for 100%.

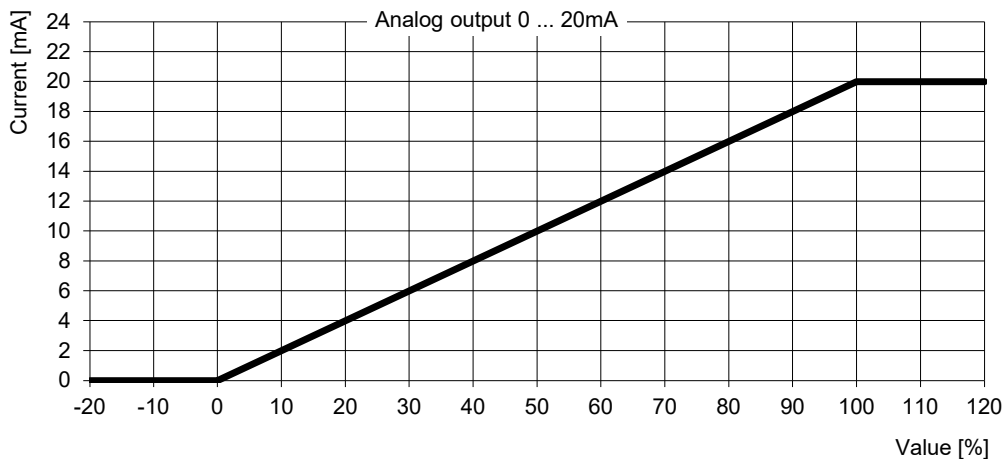

Value	Current [mA]
Smaller 0%	0
0% (min Range)	0
Between 0% and 100%	Linear interpolation from 0 ... 20 mA
100% (max Range)	20
Bigger 100%	20

Figure 10: Characteristic curve 0 ... 20mA

Characteristic curves analog output 4 ... 20mA

For the following graphic “min Range” is used for 0% and “max Range” is used for 100%.

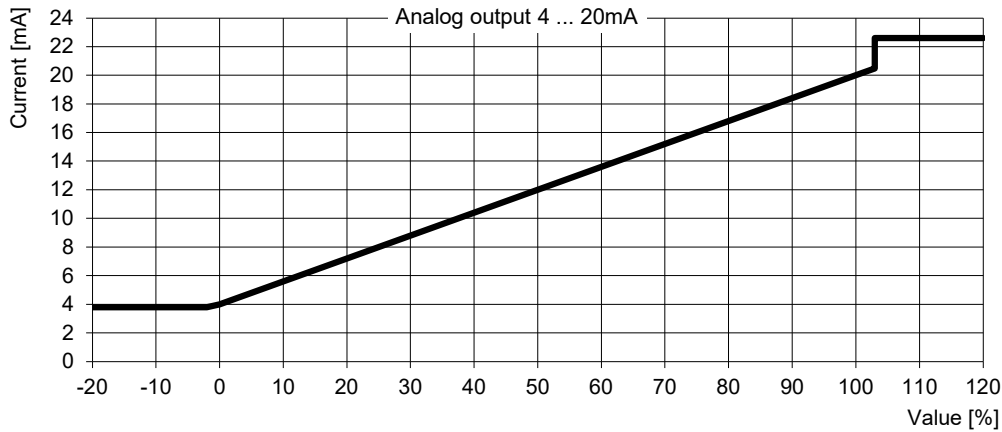

Value	Current [mA]
Empty pipe	3.5
Smaller -1.2%	3.8
Between -1.2% and 0%	Linear interpolation from 3.8 ... 4mA
0% (min Range)	4
Between 0% and 100%	Linear interpolation from 4 ... 20mA
100% (max Range)	20
Between 100% and 103%	Linear interpolation from 20 ... 20.5mA
Bigger 103%	22.6

Figure 11: Characteristic curve 4 ... 20mA

Characteristic curves analog output 0 ... 10V

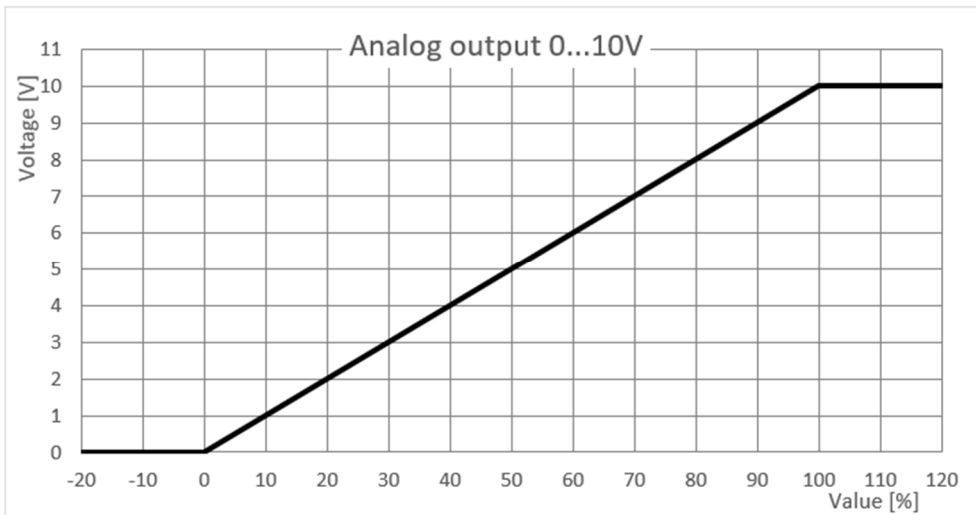

Value	Voltage (V)
Empty pipe	0
Smaller 0%	0
0% (min Range)	0
Between 0% and 100%	Linear interpolation from 0 ... 10V
Bigger 100%	10

Figure 12: Characteristic curve

3.2.2.2 Output value

Setting range: Flow

Default setting: Flow

Flow measurement for the analog output

Via the analog output the measured flow is output.

3.2.3 Digital outputs Q1 and Q2

The digital outputs Q1 and Q2 can be used as pulse output, to display the status, to signal the empty pipe message,

Setting range: Off, Pulse Output, Empty Pipe

Default setting Q1: Pulse Output

Depending on the application, NPN or PNP or Bipolar logic can be selected.

Setting range: Bipolar / PNP / NPN, normal closed / normal open

Default setting Q1: Bipolar

IMPORTANT!

With an inductive load, e.g. relays, an additional freewheeling diode must be installed antiparallel to the load.

IMPORTANT!

Example 1: Flowmax 4000i via PNP (24V), external counter e.g. PLC

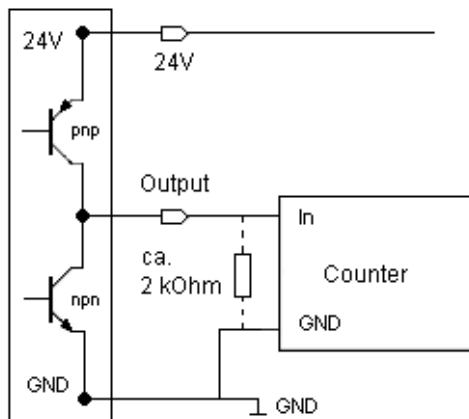

Figure 13: Connecting Digital output to counter

With high impedance input counters and highspeed counting, it may be necessary to include a resistor to have clean edges or to use bipolar configuration.

3.2.3.1 Pulse value

Choose a configuration which will neither exceed the maximum output frequency of the Flowmax 4000i (10kHz) nor the maximum input frequency of the PLC.

Example: 2.0 ml/pulse

This means: a pulse is emitted every 2.0 ml.

Setting range: 0.001 ... 50.0 ml/pulse, in steps of 0.001 ml/pulse

Default setting: ¼": 0.1 ml/pulse

⅛": 0.01 ml/pulse

3.2.4 Digital input I1

The “set offset” function is assigned to the digital input of the Flowmax 4000i as standard.

Setting range: Off, Set Offset

Default setting: Set Offset

IMPORTANT!

The “Set Offset” input function may only be carried out when the device is absolutely filled and the medium has been at a standstill for at least 30 seconds. If a Set Offset is carried out when the flow is active, incorrect measurements will occur until the adjustment has been carried out correctly. This adjustment should only be performed after the device has been powered on for more than 30 minutes.



IMPORTANT!

3.3 Overview of default settings

Function	Default settings
Pulse value	1/4": 0.1 ml/pulse 1/8": 0.01 ml/pulse
Digital output Q1	Pulse output as Bipolar
Digital input I1	Set offset
Analog output QA	Flow as 4 ... 20mA is 20mA → 1/4": 6000 [ml/min] 1/8": 1200 [ml/min]
Creeping suppression	1/4": 10 [ml/min] 1/8": 2.5 [ml/min]

3.4 General information

Please check the following before powering the flowmeter for the first time:

- Check the electrical connections and cable allocations.
- Check the installation position of the flowmeter. Is the direction of the arrow on the housing/name plate and the actual flow direction in the pipe congruent?

Once these checks have been carried out and the corresponding conditions have been checked, switch on the power supply. The device will reach optimum operating status after 30 minutes. See 3. Commissioning.

Flowmax 4000i is operational!



IMPORTANT!

4. Exchange of flowmeter

- **Switch off power before disconnecting the electrical connections!**
- **When removing the device, observe the safety instructions in chapter 2.3 Electrical wiring.**
- Please note that after replacing the flowmeter
 - a) Specific programming of the previous flowmeter should be noted and programmed to the new flowmeter



WARNING!

Repair, hazardous substances

Before sending the flowmeter Flowmax 4000i for repair, the following precautions must be taken:

- **Clean all process chemicals from the device. Fully rinse the flow path. Please pay close attention to the process fittings. All media must be removed before returning. This is particularly important, if the medium is health hazardous.**



WARNING!

Measuring devices that are not or insufficiently cleaned will be returned to the sender for cleaning without testing!

- **Always enclose a declaration of decontamination with the measuring device with as precise a description of the fault as possible, the application in which the measuring device was used and the chemical-physical properties of the measured medium.**



WARNING!

Costs resulting from insufficient cleaning of the measuring device for possible disposal or personal injury (chemical burns, etc.) will be charged to the sender of the measuring device.

To ensure that your repair order is processed quickly and efficiently, it is important that you provide us with a contact person with a phone number and e-mail address who can answer any technical questions our service staff may have.

5. Technical specifications

5.1 Dimensions and weight

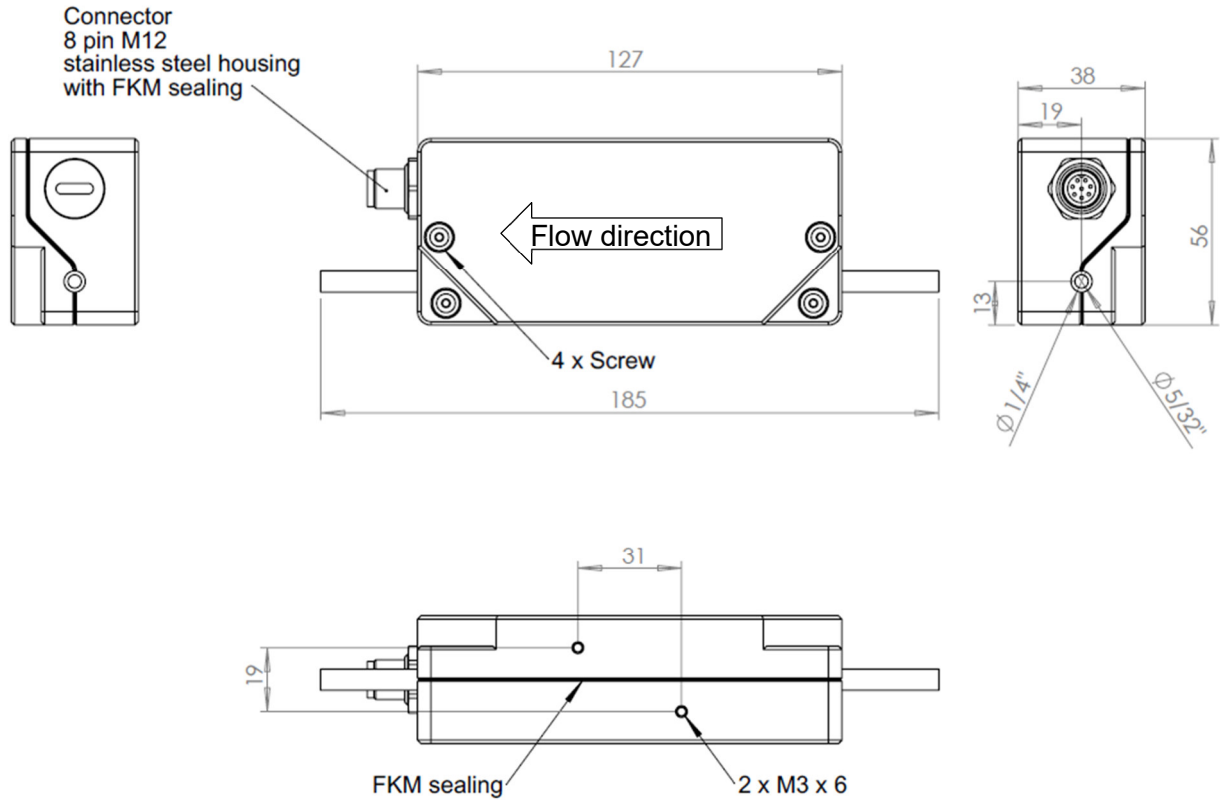

Weight: 310g

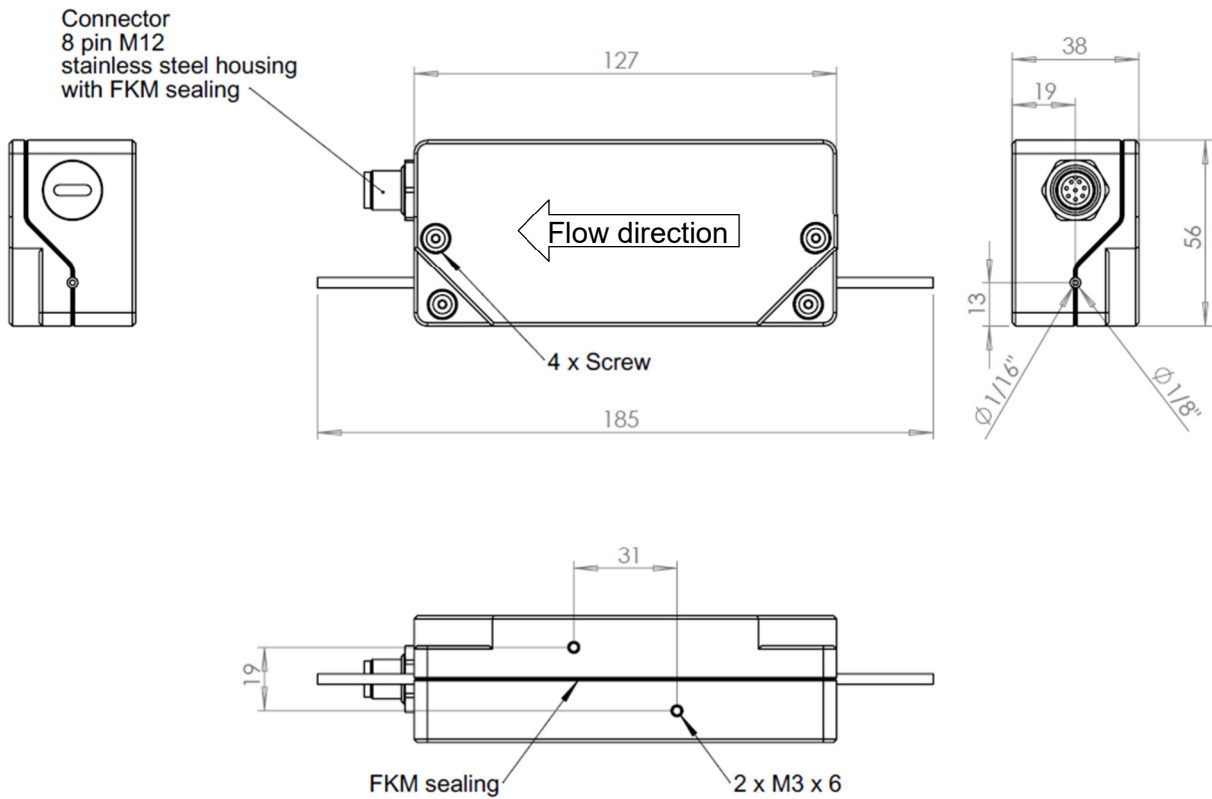

Weight: 310g

5.2 Technical specifications

Housing

Nominal diameters	1/4"; 1/8"
Process connection	Tube ends, Pillar S300 union ends, Nexus connection
Medium temperature	0 ... +60°C
Protection class	IP65
Pressure max.	6 bar
Material	
Tube	PFA
Housing	PP
Nut, sleeve	PFA

Electronics

Power supply	20 ... 30 VDC
Power input	24 VDC approx. 0.5 W
Connection	plug 8-pin
Ambient temperature	0 ... +60°C
Storage temperature	0 ... +60°C
Analog output QA	0 ... 10 V Ground connected to supply ground
Digital output Q1	via transistor, max. 100 mA output voltage according to DIN 19240: ≤5 V means LOW ≥12 V means HIGH Short cut resistant Frequency 0 ... 10 kHz
Data interface	Communication interface
Measuring deviation	± 2% o.r. ± 0.15% f.s. (o.r. = of reading, f.s. = full scale), option ± 1% o.r. ± 0.15% f.s. Reference conditions (VDE/VDI 2642)
Measuring range	1/4": 10 ... 6000 ml/min 1/8": 2.5 ... 1200 ml/min
Repeatability:	±0.5% o.r. ±0.08% f.s.

6. Accessories

Flowmax connection socket

Flowmax connection socket is used to power and connect Flowmax 4000i to an external control unit.

Ordercode	507321 (Socket 5 pins)
Ordercode	507084 (Socket 8 pins)

7. Shipment

- Flowmax 4000i

MIB GmbH
Messtechnik und Industrieberatung
Bahnhofstr. 35
D-79206 Breisach
Tel. 0049 / (0)7667 / 20 777 90
Fax 0049 / (0)7667 / 20 777 99
E-Mail: info@mib-gmbh.com
Internet: www.flowmax.de