

XA 02 E/FM400iEX2/04.2026

Valid starting from  
Hardware V 2.1  
Software V 1.29



# Flowmax<sup>®</sup> 400i

## Ultrasonic flow metering / dosing device

Ex-documentation for the  
Operating manual

According to directive 2014/34/EU  
Ex-zone 2

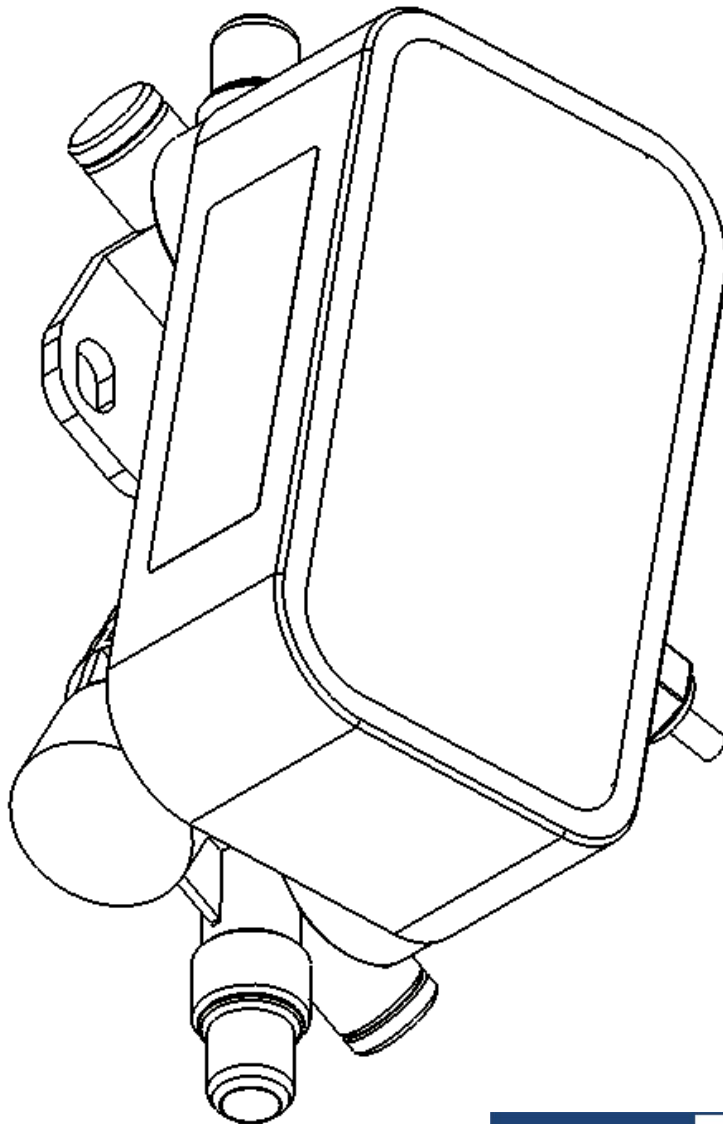



## Contents

<b>Contents</b> .....	<b>2</b>
<b>1. Variant code</b> .....	<b>3</b>
<b>2. Labelling</b> .....	<b>4</b>
<b>3. Name plate</b> .....	<b>5</b>
<b>4. Special conditions</b> .....	<b>6</b>
<b>5. Warnings</b> .....	<b>6</b>
<b>6. Additional information</b> .....	<b>6</b>
<b>7. Electrical wiring</b> .....	<b>7</b>
<b>8. Display and user menu of FlowCon 200i</b> .....	<b>9</b>
<b>9. Dimensions and weight</b> .....	<b>9</b>
<b>10. Technical specifications</b> .....	<b>10</b>



# 1. Variant code

Flowmax 400i with variant code

FM400i Dxx-FDA6xCC

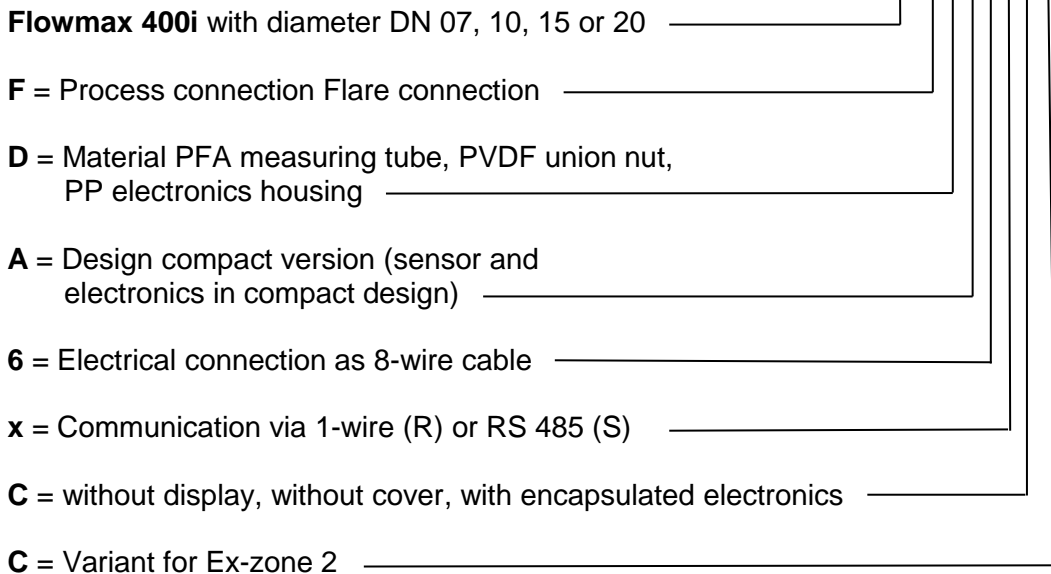

is a device within the scope of Directive 2014/34 / EU. When used as equipment of group II, category 3G for zone 2, explosive gas atmospheres, as well as in compliance with the intended use, this flowmeter does not pose any ignition hazard of its own.

The ignition hazard analysis was carried out in accordance with Directive 2014/34 / EU. Used standards are: EN 60079-0, EN60079-18.



## 2. Labelling

The EX-labelling is



II 3G Ex mc IIC T6 Gc X

With the meaning according to directive 2014/34/EU:

Device group

**II** Equipment for use in areas outside of mining (and their surface installations which may be endangered by firedamp and/or combustible dust) which may be endangered by a potentially explosive atmosphere.

Device category

**3** normal level of safety - use in zone 2 possible

Type of explosive atmosphere

**G** Mixture of air and gases, vapours or mist

according to EN 50021:

**Ex** This symbol indicates that the electrical equipment corresponds to one or more types of protection

Symbol:

**mc**

Type of protection electrical:

Encapsulation and Protection level

Standard:

EN60079-18

Explosion group (typical gases)

**IIC** (Hydrogen)

Maximum surface temperature

**T6** 85°C

**Gc** Equipment Protection Level (EPL)

corresponds to the category 3G

The symbol „X“ refers to special conditions such as a different ambient temperature

- Do not disconnect under voltage
- The medium temperature must not exceed 50°C
- The ambient / storage temperature must not exceed 50°C
- Measures must be taken to avoid electrostatic charges
- The risk of mechanical hazards is classified as low
- The measuring device must not be exposed to UV radiation



### 3. Name plate

An example of a name plate is shown below:

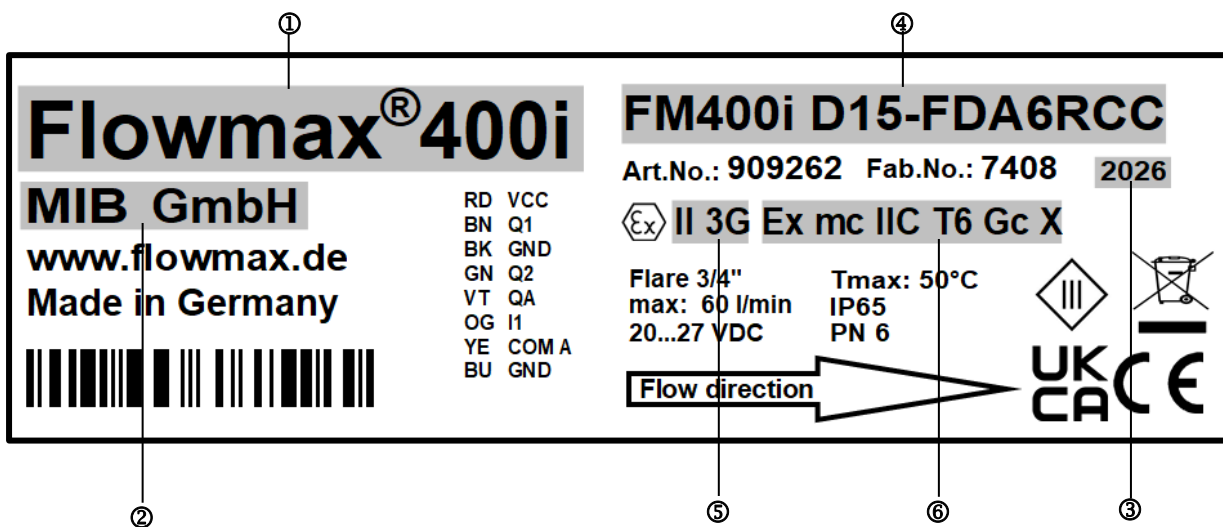

- 1 Device type
- 2 Manufacturer
- 3 Year of manufacture
- 4 Order-Code
- 5 Equipment group and category
- 6 Labelling of the type of protection and explosion group



## 4. Special conditions

The technical data and the following instructions must be observed..

- Use only for intended use
- Installation, electrical connection, commissioning and maintenance may only be carried out by personnel trained in explosion protection
- The instructions in the operating manual must be followed
- The supply voltage must be in the range 20...27 VDC
- Do not disconnect under voltage! Electrically generated sparks can ignite an explosive atmosphere. Disconnect the connecting cable outside explosive atmospheres or switch off the voltage beforehand.
- Unused electrical wires must be connected individually to unused potential-free terminal blocks
- Measures must be taken to avoid electrostatic charges



**WARNING!**

## 5. Warnings

- Assembly, electrical installation, commissioning and maintenance of the flowmeter may only be performed by trained and qualified personnel who have been instructed in explosion protection and who have been authorised by the plant operator. The qualified personnel must have read and understood the operating manual of the flowmeter including this supplementary Ex documentation and follow its instructions.
- The installer must ensure that the flowmeter is correctly connected according to the electrical connection diagrams.



**WARNING!**

## 6. Additional information

- There are no galvanically isolating components, e.g. optocouplers or relays, in the electronics.
- There are no switching contacts.
- There are no cells or batteries.
- The energy content of the ultrasonic signal transmitters/transducers on the surface to the measuring channel and the environment is below the permissible limit values according to standard EN 60079-0.

**NOTICE!**



## 7. Electrical wiring

### Cable 8-wire with 1-wire communication

Wire configuration defined by manufacturer.

The inputs and outputs can be reprogrammed for specific applications.

colour	Function	Description
Red	24 VDC	Power supply: 20...27 VDC
Brown	Digital output Q1 Functions:  1. Pulse output  2. Empty pipe output 3. Dosing output 4. Upper- or Lower limit output (limit value monitoring) 5. Negative flow	Digital output Q1 Configurable npn or pnp transistor, max. load 100mA*. Max. voltage must be less than the supply voltage. Freely adjustable ranging from 0.1 to 3000 ml/pulse in 0.1 ml/pulse steps. Configurable output of 0V or 24V when pipe is empty. Configurable output of 0V or 24V. Configurable output of 0V or 24V when reaching upper or lower limit. Configurable output of 0V or 24V when liquid flows in negative direction.
Black	GND	Ground: 0 V
Green	Digital output Q2 Functions:  1. Empty pipe output 2. Dosing output 3. Pulse output  4. Upper or lower limit output (limit value monitoring) Negative flow	Digital output Q2 Configurable npn or pnp transistor, max. load 100mA*. Max. voltage must be less than the supply voltage. Configurable output of 0V or 24V when pipe is empty. Configurable output of 0V or 24V. Freely adjustable ranging from 0.1 to 3000 ml/pulse in 0.1 ml/pulse steps. Configurable output of 0V or 24V when reaching upper or lower limit. Configurable output of 0V or 24V when liquid flows in negative direction.
Violet	Analog output QA	4...20mA; 0...20mA Example: 0l/min => 4mA 6l/min => 20mA (depending on diameter) Empty pipe Alert => 3.5mA
Yellow	Communication	Communication interface
Orange	Digital input I1 1. Dosing input 2. Set offset 3. Reset counter 4. Creeping flow off	Digital input I1 Starts the dosage by a rising edge of 24VDC. The Offset is set by a rising edge of 24VDC. Reset of the counter by a rising edge of 24VDC. Creeping suppression is deactivated as long as there are 24VDC at the input..
Blue	Shielding	EMC safety

\*it applies: for Q1 + Q2 ≤ 100mA



### Cable 8-wire with 2-wire communication

Wire configuration defined by manufacturer.

The inputs and outputs can be reprogrammed for specific applications.

Colour	Function	Description
Red	24 VDC	Power supply: 20...27 VDC
Brown	Digital output Q1 Functions:  1. Pulse output  2. Empty pipe output 3. Dosing output 4. Upper or lower limit output (limit value monitoring) Negative flow	Digital output Q1 Configurable npn or pnp transistor, max. load 100mA. Max. voltage must be less than the supply voltage. Freely adjustable ranging from 0.1 to 3000 ml/pulse in 0.1 ml/pulse steps. Configurable output of 0V or 24V when pipe is empty. Configurable output of 0V or 24V. Configurable output of 0V or 24V when reaching upper or lower limit. Configurable output of 0V or 24V when liquid flows in negative direction..
Black	GND	Ground: 0 V
Violet	Analog output QA	4...20mA; 0...20mA Example: 0l/min => 4mA 60l/min => 20mA (depending on diameter) Empty pipe Alert => 3.5mA
Orange	Digital input I1 1. Dosing input 2. Set offset 3. Reset counter 4. Creeping flow off	Digital input I1 Starts the dosage by a rising edge of 24VDC. The Offset is set by a rising edge of 24VDC. Reset of the counter by a rising edge of 24VDC. Creeping suppression is deactivated as long as there are 24VDC at the input..
Yellow	Communication	RS 485 A
Green	Communication	RS 485 B
Blue	Shielding	EMC safety

### Important!

The flowmeter Flowmax 400i may only be operated within the limits indicated on the nameplate and in the instruction manual/data sheet. Unauthorised operating conditions can lead to overload, damage or defects.



**IMPORTANT!**



## 8. Display and user menu of FlowCon 200i

Flowmax 400i in the Ex-version has no display. To display current measured values and to set application-specific parameters, the use of the display and configuration unit FlowCon 200i is required, see operating manual FlowCon 200i. This does not have an Ex-approval and may only be used outside a hazardous area.



**WARNING!**

## 9. Dimensions and weight

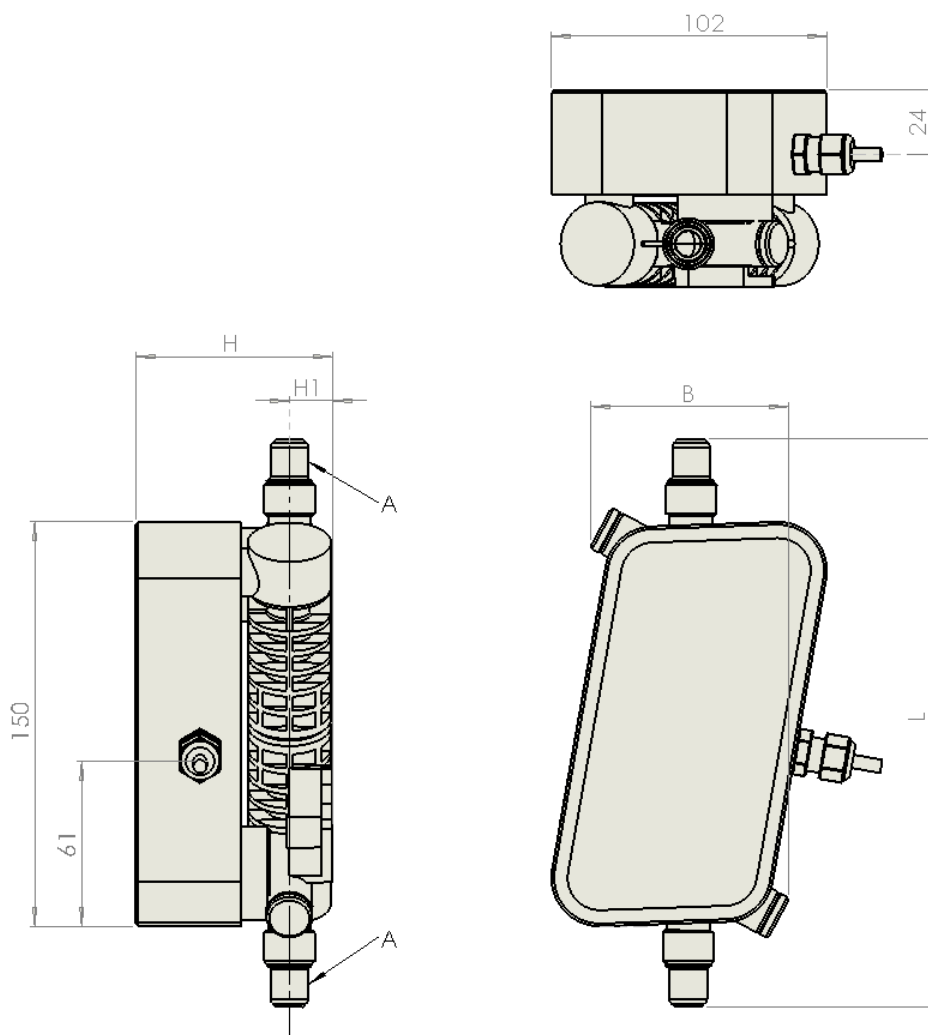

	A (für PFA Schlauch)	L [mm]	B [mm]	H [mm]	H1 [mm]	Gewicht[kg]
Flowmax 400i Ex	3/8"	209	70	73	16	1,1
Flowmax 400i Ex	1/2"	211	73	73	16	1,1
Flowmax 400i Ex	3/4"	215	87	76	19	1,1
Flowmax 400i Ex	1"	238	108	86	25	1,3



## 10. Technical specifications

### Housing

Medium temperature	0...+50°C
Protection class	IP 65
Pressure nominal	PN 6
Material	all wetted parts made of PFA Flare nut: PVDF or PFA Electronics housing: PP The risk of mechanical hazards is classified as low

### Electronics

Power supply	20...27VDC
Power consumption	at 24VDC 3.6W
Connection	cable 8-wire
Ambient temperature	0...+50°C
Storage/ Transport temperature	0...+50°C
Current output QA	0/4...20 mA, active Start and end value adjustable, Ground connected to supply ground Error signal according to NAMUR NE43 at 4...20mA
Digital output Q1/2	Transistor circuit NPN and PNP logic, max. 100mA Output voltage according to DIN 19240: ≤5V corresponds to LOW ≥12V corresponds to HIGH Short-circuit proof, in case of short-circuit the output is switched off Frequency 0...10kHz
Data interface	Communication interface
Sealing compound	Polyurethane potting / encapsulating resin

The Flowmax 400i measurement system meets the general EMC immunity requirements according to CE, EN 61000-6-3, EN 61000-4-2, EN 61000-4-3, EN 61000-4-4, EN 61000-4-5, EN 61000-4-6. It is in conformity with the requirements of the EC Directives and bears the CE label.

### Material specifications electronics housing

Non-metallic housing component	Housing material	Sealing compound
Material	Polypropylene natural	Polyurethane
Colour	Natural	PU: beige Hardener: brown
Temperature index TI (RTI) (IEC 216)	110°C	126°C
Temperature range of the application	-30...100°C	-40...125°C
Moisture absorption (ISO 62)	< 0.1%	0.4%
Flammability (UL94)	HB	V0



**MIB GmbH**  
Messtechnik und Industrieberatung  
Bahnhofstr. 35  
D-79206 Breisach  
Tel. 0049 / (0)7667 / 20 777 90  
Fax 0049 / (0)7667 / 20 777 99  
E-Mail: [info@mib-gmbh.com](mailto:info@mib-gmbh.com)  
Internet: [www.flowmax.de](http://www.flowmax.de)