

Ultrasonic Empty Pipe Detection

Flowmax® EPD 200

General safety instructions

Please always observe the following safety instructions!

Please pay attention to the safety instructions with the following pictograms and signal words in these operating instructions



IMPORTANT!

IMPORTANT! indicates situations or cases which, if not avoided, could result in damage or failure of the Flowmax EPD 200 equipment.



WARNING!

WARNING! indicates general hazardous situations or cases which, if not avoided, could result in serious injury or death.

NOTICE!

NOTICE! is used to lead users to helpful information not related to personal injury.

Intended use

- The meter Flowmax EPD 200 may only be used for measuring the flow of pure, homogeneous liquids.
- The Flowmax EPD 200 is not intended for use in medical applications.
- The meter Flowmax EPD 200 is built operationally safe in accordance with the latest state of the art technologized developments and industry standard EN 61010 regulations (corresponds to VDE 0411 "Safety specifications for electrical measurement, control and laboratory devices").
- The manufacturer is not liable for any injury, damage or harm due to inappropriate or unintended use or modifications of the flow meter. Conversions and/or changes to the flow meter may only be made, if they are expressly performed in accordance with the operating instructions in this operating manual.

Personnel for installation, commissioning and operation

- Assembly, electrical installation, commissioning and maintenance of the flow meter must be carried out by qualified, trained personnel. The qualified personnel must have read and understood the operating instructions in this operating manual and must follow the operating instructions in this manual.
- The installer has to ensure that the flow meter is correctly connected according to the electrical connection diagrams in this operating manual.
- Serious injury or death from electric shock may occur if wiring, installation, disassembly or remove of wires is performed while electrical power is energized.



Technological progress

The manufacturer reserves the right to revise, alter, or modify the flow meter to the most current technology without special prior notice. Further information about the latest updates and potential additions to these operating instructions are available from the manufacturer.

Productdescription

Flowmax EPD 200 is an empty pipe detection for use in conductive and nonconductive liquids. It is suitable as a pump protection against dry running, as a signal transmitter for 3-way-valves for switching barrels, as liquids watchman or limit switches.

Based on the ultrasonic technology Flowmax EPD 200 is able to measure conductive and nonconductive liquids contactfree. Flowmax EPD 200 has no moving parts and is absolutely free of wear.

All parts having contact to the medium are PE-HD. Flowmax EPD 200 can be used by DI-water to alkaline, toxic and/or aggressive media.

The switching output is simultaneously as npn- (0V) und pnp-(24V) output.

Additionally the state is signaled by colored LEDs:

green = pipe full, red = empty pipe

The process line is adapted via the device-side inner thread G1/2, for example suitably constructed with tube nozzle..

Serious injury or death from electric shock may occur if wiring, installation, disassembly or remove of wires is performed while electrical power is energized.

Always shut off or disconnect electrical power at service panel and lock switch or breaker and tag to prevent energizing electrical power during work or while Flowmax EPD 200 is not assembled and installed.

Wiring installation, disassembly and removal must be performed by qualified persons experienced and knowledgeable about electrical work.



Dimensions

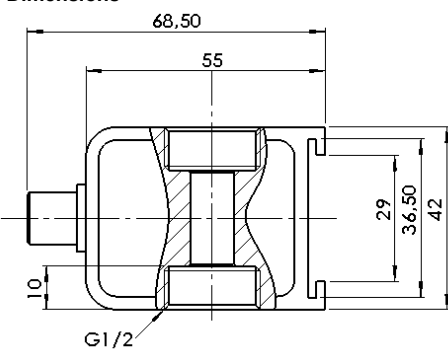

Weight: 130g

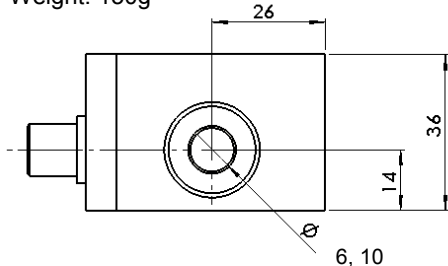

PIN assignment

Pin code: Connection plug

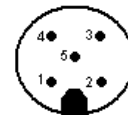

PIN	Function	Description
1	L+	Power supply: 18...30 VDC
2	Q1	Switching output Q1, pnp-transistor, closes at full pipe against Vcc
3	GND	Grounde 0V
4	Q2	Switching output Q2, npn-transistor, closes at full pipe against GND
5	--	Not used

Behavior of outputs

	LED green	LED red	Out 1 (pnp)	Out 2 (nnp)
pipe full	on	off	Vcc	GND
empty pipe	off	on	high resistance	high resistance

MIB GmbH

Bahnhofstr. 35, D-79206 Breisach
Tel. 0049 / (0) 7667 – 20 777 90
Fax: 0049 / (0) 7667 – 20 777 99
Mail: info@mib-gmbh.com
Web: www.flowmax.de
Technical subjects to be changed!

Ultrasonic Empty Pipe Detection Flowmax® EPD 200

Operating manual
BA 003E/EPD200/06.18

The wiring is to prove.

Inductive load on the digital outputs without an installed diode may cause damage on the Flowmax EPD200 electronics.
The output current from digital output has not run over 100mA.

